



## FTS-C12G-10M

1000Base-T RJ45 SFP module, 100 meters



### Description

FTS-C12G-10M SFP transceiver can be used to setup a reliable Gigabit Ethernet link over UTP cable (cat. 5e or higher). Maximum transmission distance can reach up to 100 meters. This module uses SerDes electrical interface on the host side. Host device can access module internal EEPROM and PHY configuration registers via I<sup>2</sup>C interface (address A0h for EEPROM, ACh for PHY registers). Module is fully compatible with SFP MSA (INF-8074i 1.0) and it is available in four versions:

Model	LOS Pin	Operating temperature range
FTS-C12G-10M	No	0~70°C
FTS-C12G-10M#	Yes	0~70°C
FTS-C12G-10MI	No	-40~85°C
FTS-C12G-10MI#	Yes	-40~85°C

Transceiver can be prepared as compatible with: Cisco, HP, Netgear, Avaya, D-Link, Brocade, Extreme Networks, Huawei, Enterasys, 3Com, Alcatel-Lucent and other. To confirm compatibility please contact technical support before ordering.

### Applications

- Gigabit Ethernet (1.25Gb over Cat. 5e or higher)
- Other serial link connections



## Key features

- RJ45 connector
- Transmission distance up to 100m
- Throughput 1.25Gb/s (Gigabit Ethernet)
- Fully compliant with SFP MSA INF-8074i rev. 1.0 and INF-8472 rev. 11.3 (where applicable)
- Hot-Pluggable
- RoHS compliant
- Low power dissipation
- Metal case for low EMI
- Operating case temperature: 0~70°C / -40~85°C \*

## Specification

### Supported transmission technology

Gigabit Ethernet

### Speed supported for Ethernet technology

1.25Gbps

### Speed supported for Fibre Channel technology

N/A

### Transmission medium

UTP cable (Cat.5e or greater)

### Transmission distance

up to 100m

### Receptacle type

RJ45

### Wavelength

N/A

### Output power

N/A

### Receiver sensitivity

N/A

### Power supply voltage

3.3V

### Total power consumption

< 1W

### Operating environment – temperature\*

0~70°C / -40~+85°C

### Operating environment - humidity

5~95% non-condensing

### Dimensions

56.5mm × 13.5mm × 8.9mm

\* - standard industrial



## Detailed technical specification

### Pin Description

Pin	Name	Function/Description	Engagement order	Notes
1	VeeT	Transmitter Ground	1	-
2	TX Fault	Transmitter Fault Indication	3	
3	TX Disable	Transmitter Disable-Module disables on high or open	3	1
4	MOD-DEF2	Module Definition 2-Two wire serial ID interface	3	2
5	MOD-DEF1	Module Definition 1-Two wire serial ID interface	3	2
6	MOD-DEF0	Module Definition 0-Grounded in module	3	2
7	Rate Select	Not Connected	3	-
8	LOS	Loss of Signal	3	3
9	VeeR	Receiver Ground	1	-
10	VeeR	Receiver Ground	1	-
11	VeeR	Receiver Ground	1	-
12	RD-	Inverse Received Data out	3	4
13	RD+	Received Data out	3	4
14	VeeR	Receiver Ground	1	-
15	VccR	Receiver Power - +3.3V±5%	2	5
16	VccT	Transmitter Power - +3.3 V±5%	2	5
17	VeeT	Transmitter Ground	1	-
18	TD+	Transmitter Data In	3	6
19	TD-	Inverse Transmitter Data In	3	6
20	VeeT	Transmitter Ground	1	-

#### Notes:

- TX Disable input is used to shut down the PHY. It is pulled up within the module with a 4.7 – 10K resistor.
  - Low (0 – 0.8V): PHY Enabled
  - Between (0.8V and 2V): Undefined
  - High (2.0 – VccT): PHY Disabled
  - Open : PHY Disabled
- Mod-Def 0, 1, 2. These are the module definition pins. They should be pulled up with a 4.7KΩ-10KΩ resistor on the host board to supply less than VccT+0.3V or VccR+0.3V.
  - Mod-Def 0 is grounded by the module to indicate that the module is present.
  - Mod-Def 1 is clock line of two wire serial interface for optional serial ID.
  - Mod-Def 2 is data line of two wire serial interface for optional serial ID.
- LOS (Loss of Signal) is not available and tied to ground in FTS-C12G-10M and FTS-C12G-10MI
- RD-/+ : These are the differential receiver outputs. They are AC coupled 100Ω differential lines which should be terminated with 100Ω differential at the user SERDES. The AC coupling is done inside the module and thus not required on the host board.
- VccR and VccT are the receiver and transmitter power supplies. They are defined as 3.3V±5% at the SFP connector pin. The in-rush current will typically be no more than 30mA above steady state supply current after 500ns.
- TD-/+ : These are the differential transmitter inputs. They are AC coupled differential lines with 100Ω differential termination inside the module. The AC coupling is done inside the module and is thus not required on host board.



## Electrical parameters

Parameter	Symbol	Minimal	Typical	Maximum	Unit	Notes
Module Supply Current	Icc	-	-	400	mA	-
Transmitter Differential Input Voltage (TD +/-)	-	500	-	2400	mV <sub>P-P</sub>	1
Receiver Differential Output Voltage (RD +/-)	-	500	-	2000	mV <sub>P-P</sub>	2
Differential Input Impedance	ZTX	80	100	120	Ω	
Low speed output: Transmitter Fault (TX_FAULT) / Loss of Signal (LOS)	VOH	2.0	-	V <sub>CC</sub>	V	3
	VOL	0	-	0.8	V	-
Low speed input: Transmitter Disable (TX_DISABLE), MOD_DEF 1, MOD_DEF 2	VIH	2.0		V <sub>CC</sub>	V	4
	VIL	0		0.8	V	-
Data Output Rise/Fall Time	tr,Rx/ tf,Rx		180		ps	-

### Notes:

1. Internally AC coupled and terminated to 100Ω differential load.
2. Internally AC coupled, but requires a 100Ω differential termination or internal to Serializer/Deserializer.
3. Mod\_Def1 and Mod\_Def2 must be pulled up externally with a 4.7KΩ-10KΩ resistor on the host board to V<sub>CC,T,R</sub>.

## Mechanical specification

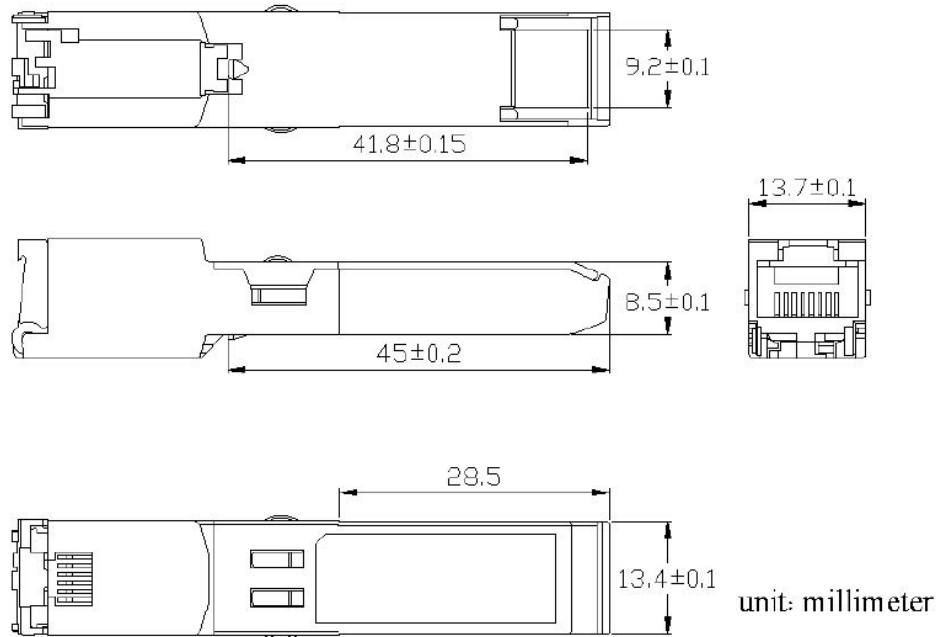



## Recommended environment conditions

Parameter	Symbol	Min	Typ	Max	Unit
Operating Temperature Range (industrial)	T	-40	-	85	°C
Operating Temperature Range (standard)	T	0	25	70	°C
Supply Voltage	V <sub>CC</sub>	3.135	3.3	3.465	V
Relative Humidity	RH	5	-	95	%

## Ordering information

FTS-C12G-10M – RJ45 SFP, 100m UTP, 1000Mbps (SerDes), commercial temperature (0~70°C)

FTS-C12G-10M# – RJ45 SFP, 100m UTP, 1000Mbps (SerDes), enabled LOS Pin, commercial temperature (0~70°C)

FTS-C12G-10MI– RJ45 SFP, 100m UTP, 1000Mbps (SerDes), industrial temperature (-40~85°C)

FTS-C12G-10MI#– RJ45 SFP, 100m UTP, 1000Mbps (SerDes), enabled LOS Pin, industrial temperature (-40~85°C)

For further information regarding host device PCB layout recommendation, power supply requirements, EEPROM memory map please check:

[SFF-8472 - Description of EEPROM and Digital Diagnostic Monitoring Interface](#) and [INF-8074 - Technical specification for SFP transceiver](#)

For PHY registers description and configuration please check Marvell Alaska PHY 88E1111 Datasheet

Fibrain Sp. z o.o. reserves the right to make changes to the products or information contained herein without notice. No liability is assumed as a result of their use or application.

Pictures used for reference only, actual product look may differ. For most actual information please contact technical support via [aktywa@fibrain.pl](mailto:aktywa@fibrain.pl)